

View from "A"

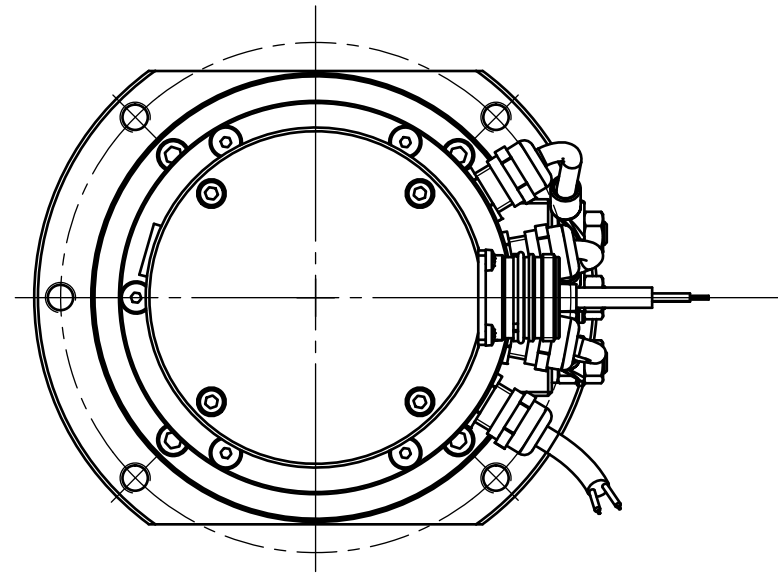

View with wheel and frame plate

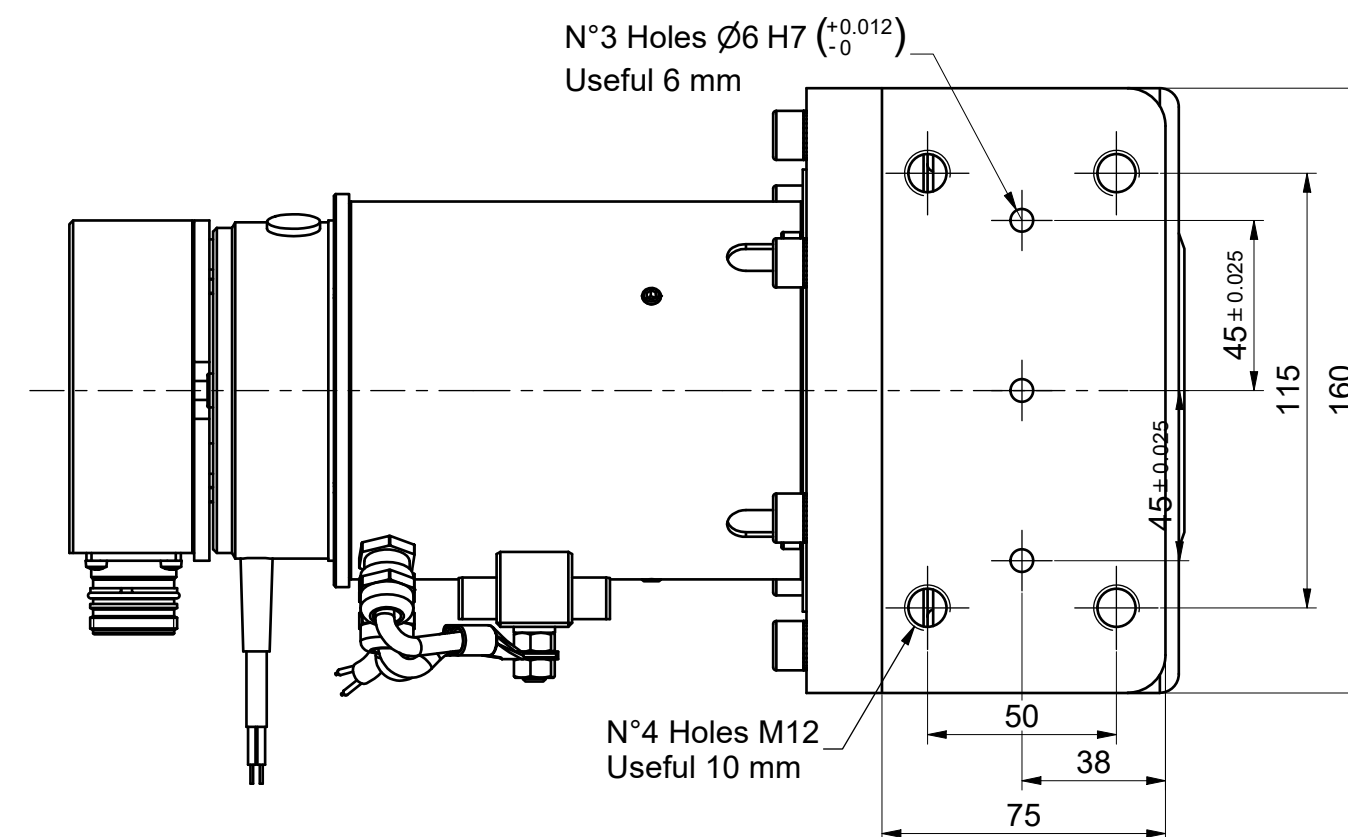
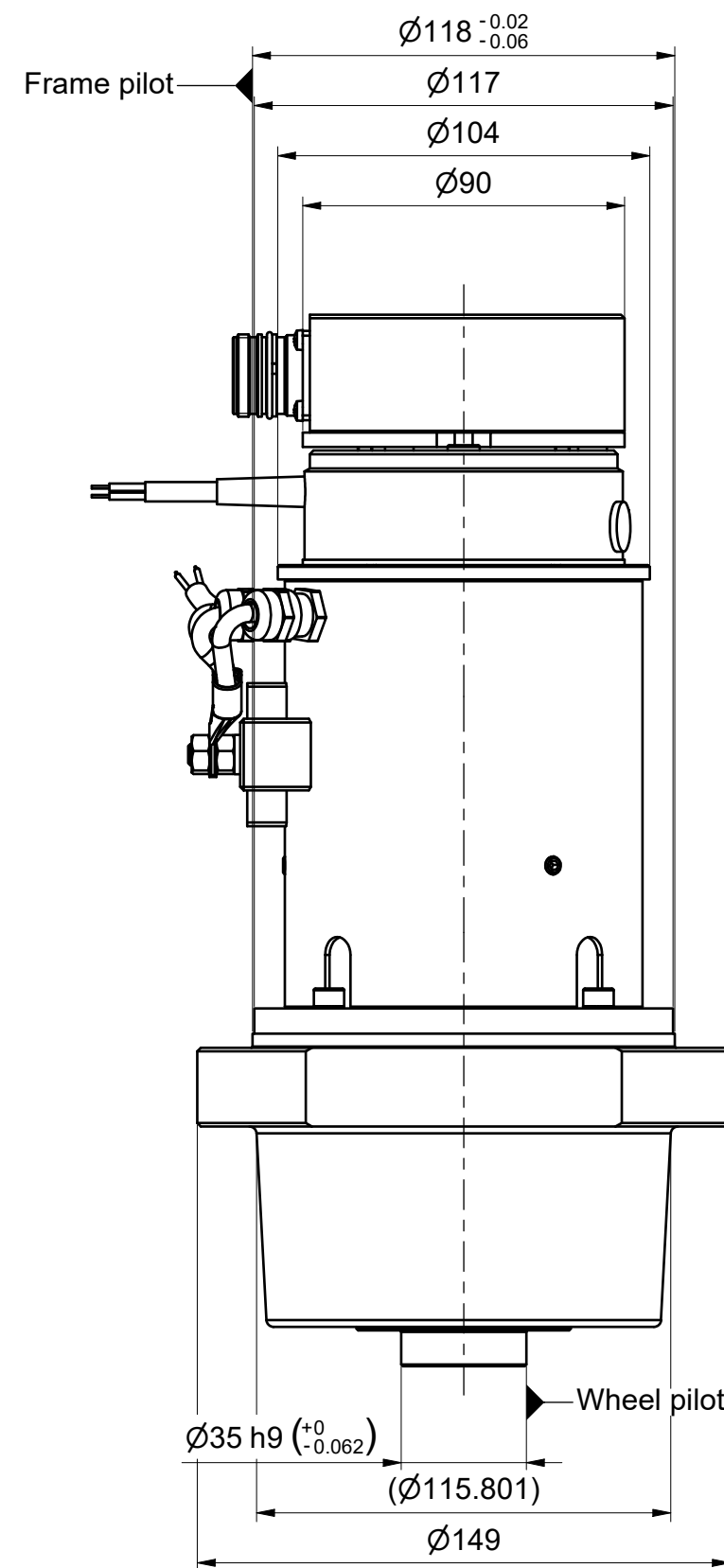
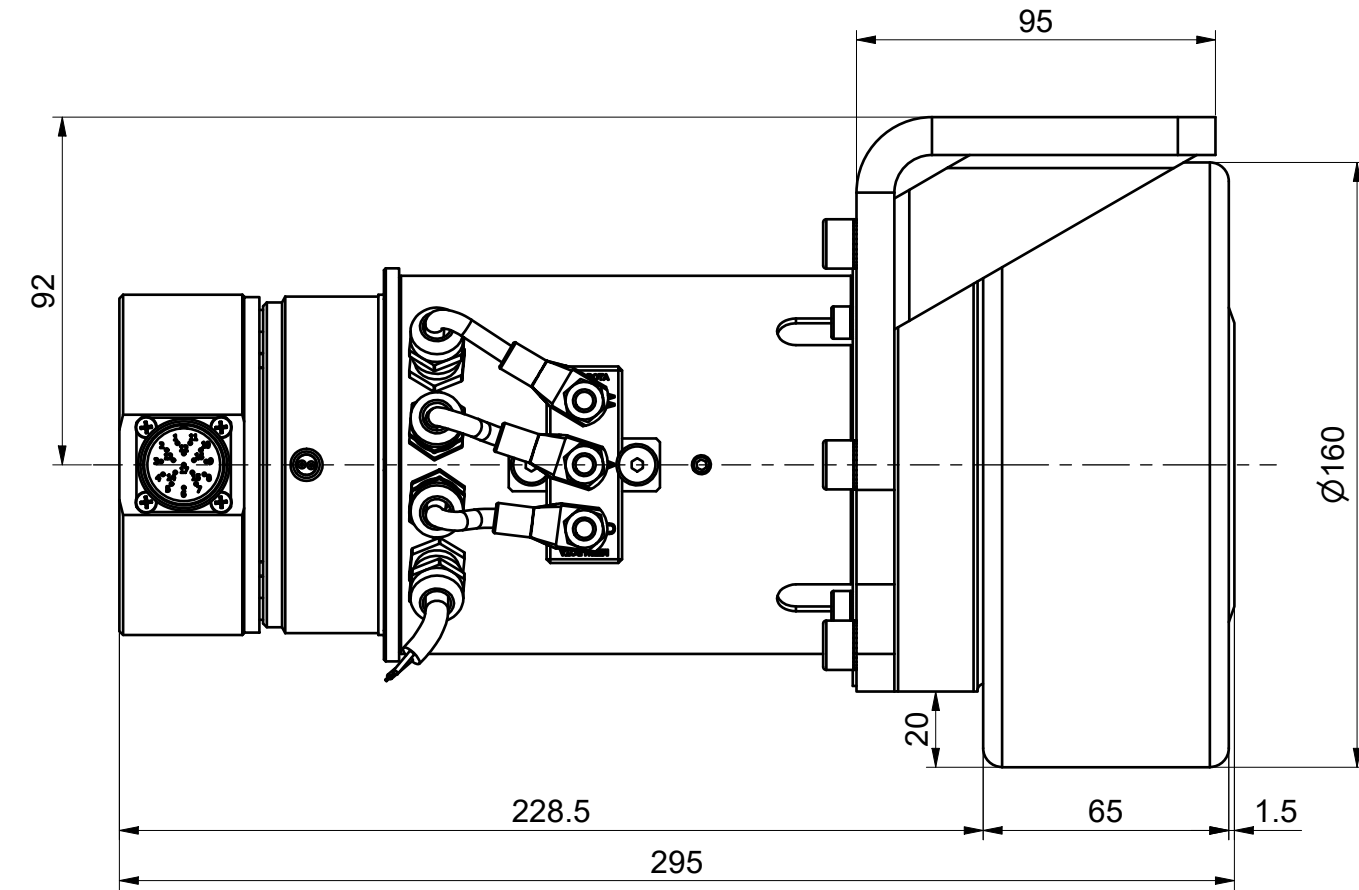
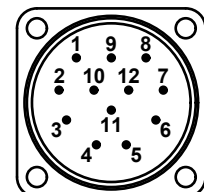
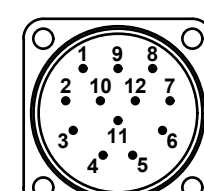

Types of connections	
Resolver	
Pin	Description
1	Cos -
2	Sin +
3	Sin -
4	NC
5	Shield
6	Cos +
7	Ref +
8	NC
9	Pt1 (Thermal)
10	Pt2 (Thermal)
11	Ref -
12	NC
	
MRSINCOS47	
Pin (Cables)	Description
1 (NA)	NC
2 (White)	Sin+ Va
3 (NA)	NC
4 (NA)	NC
5 (Black)	Shield
6 (Blue)	Cos +
7 (Red)	Ref + 5 VDC
8 (NA)	NC
9 (Red)	Pt1 (Thermal)
10 (Black)	Pt2 (Thermal)
11 (NA)	Ref -
12 (NA)	NC
	

E/m brake	
Wire	Function
Brown	+
Black	-

Gear data		
Available reduction ratio	i	12.57:1 23.4:1
Output torque ratings		
Continuous	Intermittent	
140 Nm	220 Nm	
Lubrication type	Grease	
Weight	kg	12

Types of wheels available		
Dimensions and max loads		
Ø160x65 mm 500 kg	Ø200x65 mm 600 kg	
Wheels material	Polyurethane	
Tread available	Smooth Grooved	
Hardness	Sh	90
Other materials, hardness, dimensions and tread of wheels are available on request.		

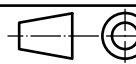
A2	Date: 14/01/2021	
	Designer: L.L.	